

Wooden jack kit

Instructions

Rigging

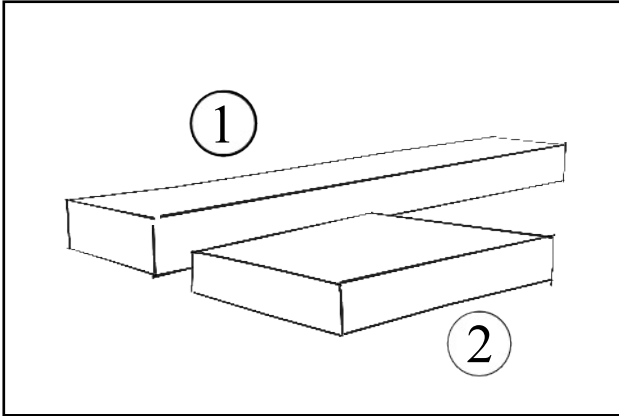

The kit contains:
A large wooden block, marked 1.
A small wooden block marked 2.

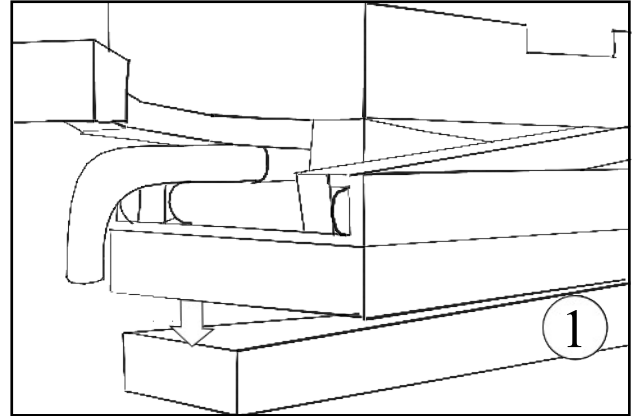

Place the block 1 under the end of the ramp,
as shown on the drawing.

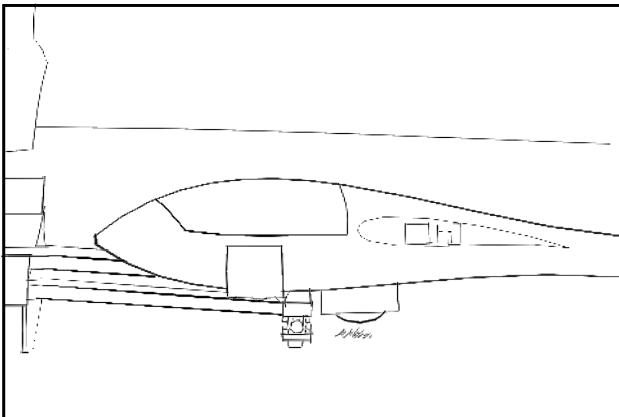

Pull out the fuselage, and extend the
undercarriage. Block 1 should prevent the
wheel from touching the ground, by app. 1 cm
Making undercarriage extension possible.

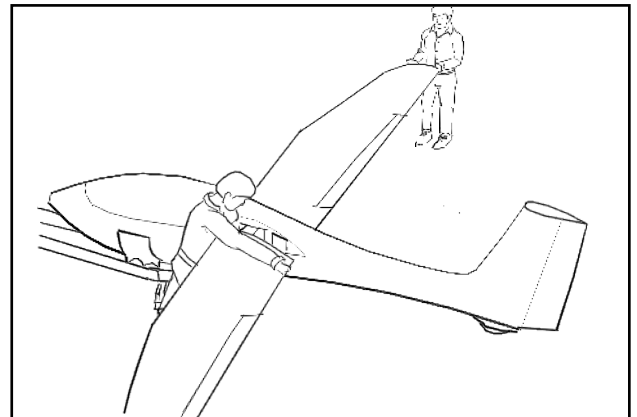

Rig the glider in the normal fashion.

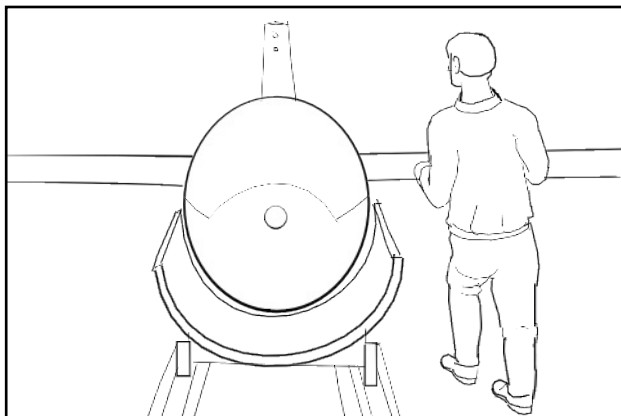

Push the glider out of its support and onto the
wheel.

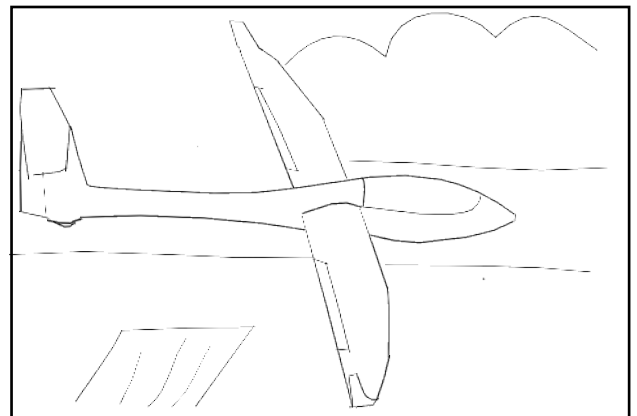

Have fun flying.

Wooden jack kit

Instructions

De-rigging

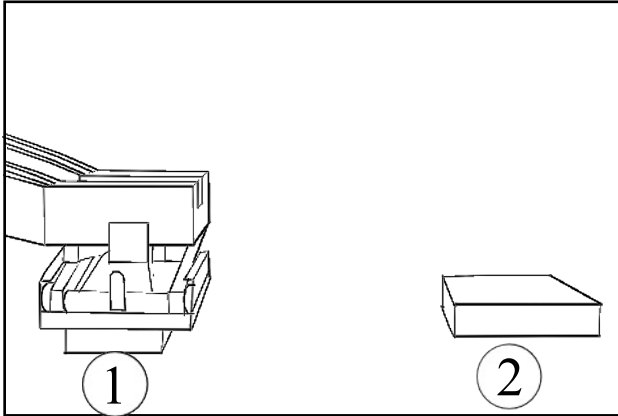

Place block 1 under the ramp, and block 2 About 30 cm in front of the ramp.

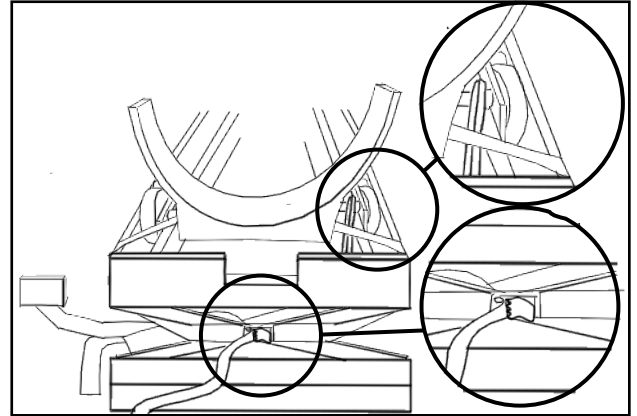

Take the strap and secure the fuselage support. Make sure the pin does not block the support from going into the trailer.

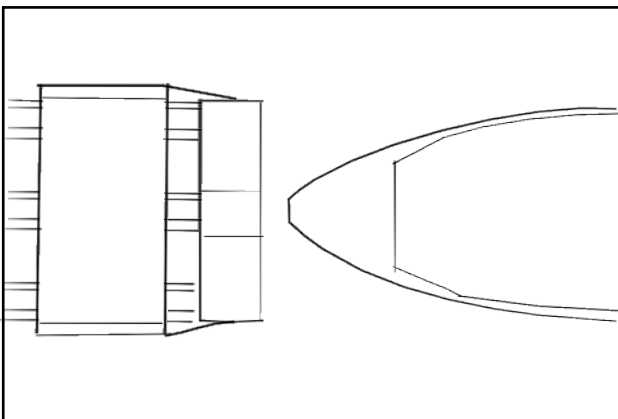

Align the glider with the ramp.

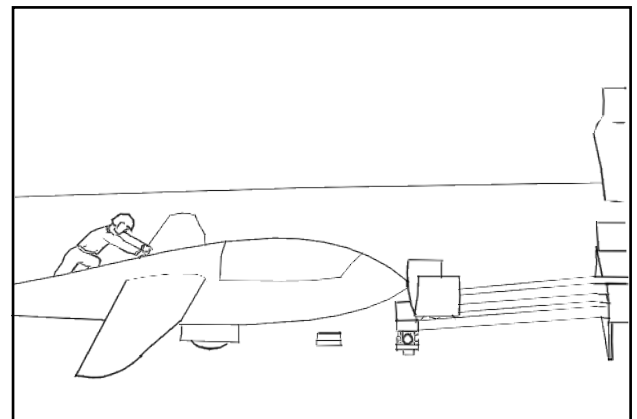

Build up momentum in the glider, by pushing it from a distance.

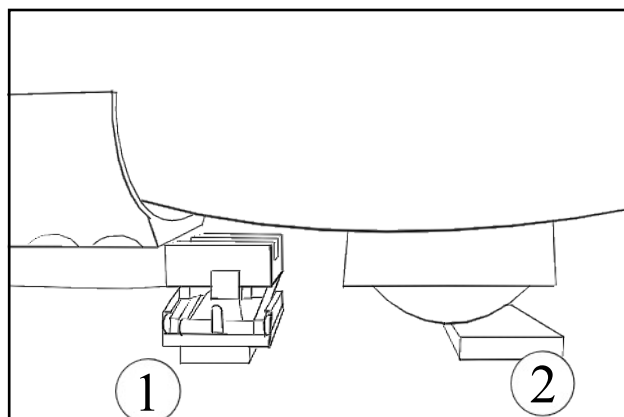

The glider should now roll onto block 2, lifting it over the fuselage support, and setting it down at the right position.

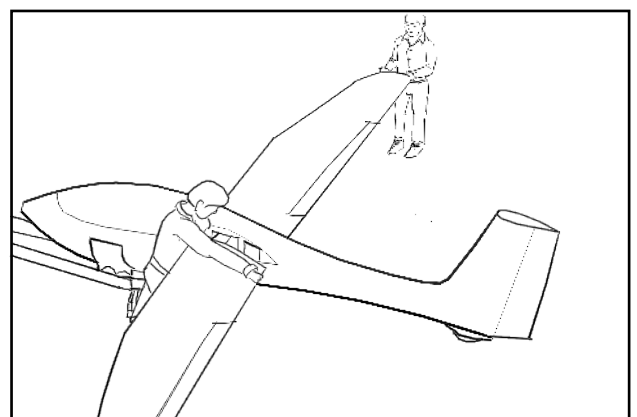

The glider can now be de-rigged in normal fashion.